

INSTRUCTIONS

DOWNLIGHTS EMERGENCY DRIVER INSTALLATION

RAB®

RAB Lighting is committed to creating high-quality, affordable, well-designed and energy-efficient LED lighting and controls that make it easy for electricians to install and end users to save energy. We'd love to hear your comments. Please call the Marketing Department at 888-RAB-1000 or email: marketing@rablighting.com

**** DON'T TOSS IT—RECYCLE IT! MAKE THE SUSTAINABLE CHOICE BY RECYCLING THIS FIXTURE AT END OF LIFE WITH A LICENSED RECYCLING PROVIDER. ****



EMB-9 EMB-15



EMB-25

IMPORTANT

READ CAREFULLY BEFORE INSTALLING DRIVERS. RETAIN THESE INSTRUCTIONS FOR FUTURE REFERENCE.

RAB drivers must be wired in accordance with the National Electrical Code and all applicable local codes. Proper grounding is required for safety. THIS PRODUCT MUST BE INSTALLED IN ACCORDANCE WITH THE APPLICABLE INSTALLATION CODE BY A PERSON FAMILIAR WITH THE CONSTRUCTION AND OPERATION OF THE PRODUCT AND THE HAZARDS INVOLVED.

TO PREVENT ELECTRICAL SHOCK, POWER SHOULD BE TURNED OFF AT THE FUSE BOX BEFORE INSTALLATION.

WARNING

1. To prevent high voltage from being present on the brown and blue output leads prior to installation. The emergency driver connector must be open. Join the unit connector after the emergency driver has been installed and before the AC power is supplied.
2. Make sure all connections are in accordance with the National Electrical Code or any local regulations.
3. To reduce the risk of electric shock, disconnect both normal and auxiliary power supplies and unit connector of the emergency driver before servicing.
4. An AC power source (100-347VAC,50/60Hz) ahead of any wall switch is required to provide battery charging current.
5. Do not install near gas or electric heaters.
6. This product is for use with indoor or damp locations where ambient temperature is (0°C to 50°C). It is not suitable for wet or hazardous locations.
7. DO NOT USE OUTDOOR. For use with grounded,UL Listed, damp location rated, indoor fixtures and case should be grounding. The driver are intended for ordinary locations and for permanent installation into one or more Listed emergency luminaires. This equipment has not been investigated for use in an air handling fixture. Do not use in heated air outlets or hazardous locations.
8. This is a sealed unit. Integral battery is not replaceable. Replace entire unit when necessary.
9. The use of accessory equipment not recommended by the manufacturer may cause an unsafe condition.
10. Servicing should be performed by qualified service personnel.
11. Equipment should be mounted in locations and at heights where it will not be subjected to tampering by unauthorized personnel. Indicator light should be mounted can see location.
12. Equipment only use for LED lighting emergency backup. Do not use this equipment for other than its intended use.
13. The weight of the equipment should be considered before installation, The weight of both EMB-09 and EMB-15 is 1.59 lbs each, while the EMB-25 weighs 2.38 lbs.
14. The equipment must be used for normal use of the matching luminaires.
DLC website - <https://www.designlights.org/search>
Energy star fixture website - <https://www.energystar.gov/productfinder/product/certified-light-fixtures/results>
Follow industry standard by utilizing available. ies files and lighting design software for your dedicated emergency luminaires, with the above calculated emergency lumens, and validate your as-installed plans in accordance with the applicable life safety codes governing your project. While the emergency driver has been found compliant with the requirements of UL924, it is ultimately the responsibility of the Designer/Specifier to assure the as-installed system delivers code-compliant path of egress illumination in accordance with Federal, State or local municipal requirements.

This product contains a rechargeable lithium ion battery. THE BATTERY MUST BE RECYCLED OR DISPOSED OF PROPERLY TO PREVENT

CAUTION

- Caution: to reduce the risk of electric shock-disconnect both normal and emergency sources within this unit before servicing any equipment connected to this unit.
- CAUTION: See instruction manual for installation, operating, and maintenance instructions.
- Suitable for use in damp locations.
- For use with led luminaires identified in the manufacturer's installation instructions.
- caution: sealed unit. Battery not replaceable. Replace entire unit when necessary.

INSTRUCTIONS

DOWNLIGHTS EMERGENCY DRIVER INSTALLATION

RAB®

RAB Lighting is committed to creating high-quality, affordable, well-designed and energy-efficient LED lighting and controls that make it easy for electricians to install and end users to save energy. We'd love to hear your comments. Please call the Marketing Department at 888-RAB-1000 or email: marketing@rablighting.com

**** DON'T TOSS IT—RECYCLE IT! MAKE THE SUSTAINABLE CHOICE BY RECYCLING THIS FIXTURE AT END OF LIFE WITH A LICENSED RECYCLING PROVIDER. ****

OPTIONAL ACCESSORIES

The T-BAR mounting bracket is sold separately as an optional accessory kit (*BRACKET/TG/DRI*). Call our experts at 888 722-1000 for more information.

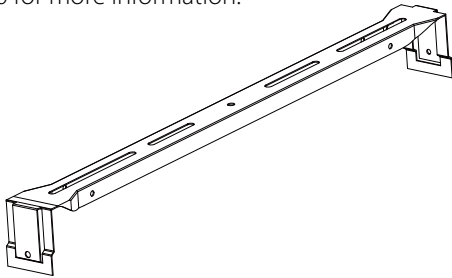

MOUNTING METHODS

Mounting Method 1

With T-BAR mounting bracket (*Fig.1*)

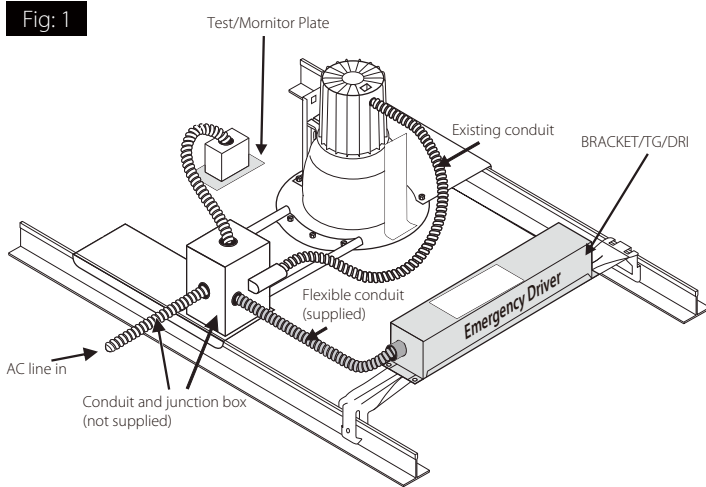

Mounting Method 2

With Straps (*Fig.2*)

Run the straps through the mounting tabs of the unit for securing to a beam or column near the fixture. Multiple strap kits can be used in conjunction with each other for larger diameter requirements.

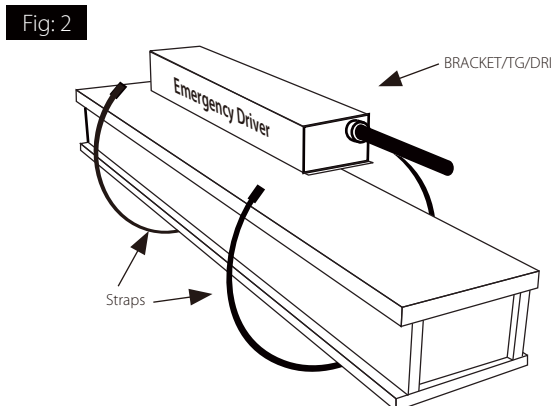

INSTALLATION INSTRUCTIONS

NOTE:

1. The emergency driver will be located between the AC power sources and the AC driver as shown in wiring diagram section of instructions.
2. The emergency driver may be installed in close proximity to the fixture or remote from the fixture.
3. The maximum remote distance using 18AWG wire is 250ft.
4. The AC power is fed to the emergency driver.
5. The AC driver receives power from the emergency driver. Identify the output wires of the emergency driver by the presence of the purple and blue leads.

STEP 1: DISCONNECT AC POWER FROM FIXTURE

1. Disconnect all power sources from lighting fixture and ensure they are locked out during installation or maintenance.
2. Disconnect power leads from the AC driver.
3. Select a suitable location for the emergency driver and install such that its output leads can connect to the input leads of the AC driver.
4. For typical installation and select appropriate mounting method.

STEP 2: WIRING THE EMERGENCY DRIVER

1. Use the wiring diagram found as reference.
2. Connect the AC power source leads to the input of the emergency driver
3. Connect the output leads of the emergency driver to the AC driver.
4. Wire the AC driver with the lamp in accordance with manufactures installation instructions.
5. Make sure all connections are in accordance with the National Electrical Code, and any local regulations.
6. To reduce the risk of electric shock, Disconnect both the branch circuit-breakers or fuses and the emergency driver connector supply before servicing."

STEP 3: MOUNTING THE TEST ACCESSORIES

1. Red wire of emergency backup into the switch box.
2. Connect same color the gray wire and red wire of indicator light, fix the panel switch to switch box.
3. The indicator light and test switch maybe mount into fixture.

STEP4: JOIN THE CONNECTOR & APPLY POWER

1. After installation is complete, join the emergency driver connector and apply AC power.
2. At this point, power should be connected to both the AC driver and the emergency driver and the Charging Indicator Light should illuminate indicating the battery is charging.
3. At short-term discharge test may be conducted after the emergency driver has been charging for 2 hours. Charge for 24 hours before conducting a long term discharge test. Refer to operation.

INSTRUCTIONS

DOWNLIGHTS EMERGENCY DRIVER INSTALLATION



RAB Lighting is committed to creating high-quality, affordable, well-designed and energy-efficient LED lighting and controls that make it easy for electricians to install and end users to save energy. We'd love to hear your comments. Please call the Marketing Department at 888-RAB-1000 or email: marketing@rablighting.com

**** DON'T TOSS IT—RECYCLE IT! MAKE THE SUSTAINABLE CHOICE BY RECYCLING THIS FIXTURE AT END OF LIFE WITH A LICENSED RECYCLING PROVIDER. ****

OPERATION

During normal operation, AC power is supplied to the AC driver through the emergency driver and charges the battery. The emergency driver AC input line voltage (100-347AC) and automatically sets the output voltage during emergency mode. When AC power fails, the emergency driver automatically switches to emergency mode, keeping the load illuminated for a minimum of 90 minutes. When AC power is restored, the emergency driver returns to charging mode. The emergency driver consists of a low-battery voltage disconnect which is reset when AC power is restored.

MAINTENANCE

Although no routine maintenance is required to keep the emergency driver functional, it should be checked periodically to ensure that it is working.

The following schedule is recommended:

1. Visually inspect the charging indicator light monthly. It should be illuminated.
2. Test the emergency operation of the fixture at 30-day intervals for a minimum of 30 seconds. The lamp should operate at full illumination.
3. Conduct a 90-minute discharge test once a year. The lamp should operate at full illumination for at least 90 minutes.
4. This red indicator flashes or off, the emergency power supply is abnormal.
5. If the emergency power supply is abnormal after the first installed please charge for 2 hours and then check if it is normal.

SPECIFICATION

Models	Load Range w/o 10V	Load Range w/o 0-10V
EMB-9	6-80W	6-9W
EMB-15	6-120W	6-15W
EMB-25	10-220W	10-25W

Note:

1. Not Compatible with Sensor fixtures
2. These instructions do not cover all details or variations in equipment nor do they provide for every possible situation during installation, operation or maintenance.

WIRING DIAGRAM

Note:

1. Make sure the necessary branch circuit wiring is available. An unswitched source of power is required.
2. The indicator light has three working modes: ON, OFF, and flashing. The indicator light displays red color
3. The 3 wires reserved for Sensor connection can be left floating if the product is not equipped with a Sensor. For products with an integrated Sensor, please refer to the official RAB website to verify compatibility before wiring.

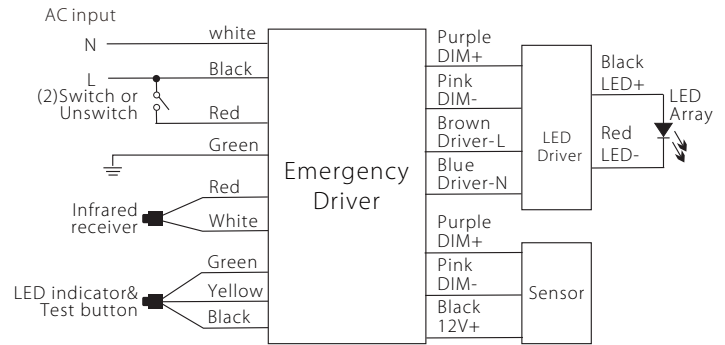

DIMENSIONAL DRAWINGS

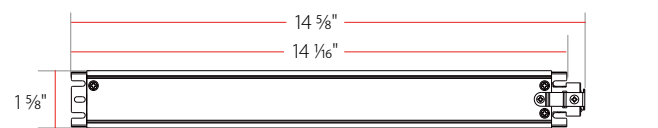

EMB-9 EMB-15

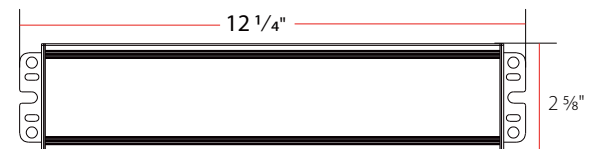
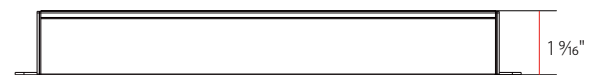

EMB-25



Easy Answers

rablighting.com
Visit our website for product info

Tech Help Line
Call our experts: 888 722-1000

e-mail
Answered promptly - sales@rablighting.com

Free Lighting Layouts
Answered online or by request