

LM-79-08 Test Report

For

RAB LIGHTING INC

(Brand Name : RAB)

170 Ludlow Ave , PO BOX 970, Northvale, NJ 07647-2305 USA

Model name(s) :

DLG0018(GF4)

Report Type: Testing and Report According to IES LM-79-2008

Type of Luminaire: Downlights

Report Date: 2023-06-21

1.1 Rated Values:	
Rated Voltage / Frequency	120V, 60HZ
Nominal Power	12W
Rated Initial Lamp Lumen	790lm (2700k) , 850lm (3000k)
Declared CCT	2700k/3000k/3500k/4000k/5000k

1.2 Test Specifications:

Test item	<ol style="list-style-type: none"> 1. Total Luminous Flux 2. Luminous Distribution Intensity 3. Luminous Efficacy 4. Correlated Color Temperature 5. Color Rendering Index 6. Chromaticity Coordinate 7. Electrical Parameters
Reference Standard	<ol style="list-style-type: none"> 1. IES LM-79-2008 Electrical and Photometric Measurements of Solid-State Lighting Products 2. ANSI C78.377-2015 Specifications for the Chromaticity of Solid State Lighting Products 3. CIE 13.3-1995 Method of Measuring and Specifying Colour Rendering Properties of Light Sources 4. CIE 15-2004 Technical Report Colorimetry 5. IESNA LM-16-93 Practical Guide to Colorimetry of Light Source 6. IESNA TM-16-05 Technical Memorandum on Light Emitting Diode (LED) Sources and Systems
Reference Work Instruction	QD25

1.3 Test Methods

<p>1) Photometric and Light Distribution Measurement – Goniophotometer Method:</p> <p>Photometric parameters were measured using the goniophotometer and software. The ambient temperature shall be maintained at 25°C ±1°C, measured at a point not more than 1 m from the sample and at the same height as the sample. The sample was operated at 120 or rated Volts AC, 60Hz. It was stabilized before measurement was made. Luminous flux, luminaire efficacy, zonal lumen were calculated from the software taken at 1°vertical intervals and 22.5°horizontal intervals.</p>
<p>2) Chromaticity Measurement – Sphere-Spectroradiometer Method:</p> <p>Chromaticity parameters were measured using an integrating sphere, a spectroradiometer and software. The ambient temperature condition inside the sphere was maintained at 25°C ±1°C. The sample measurements were made using a spectroradiometer connected by a fiber optic cable and detector through the detector port of the integrating sphere. The sample was operated at 120 or rated Volts AC, 60Hz. It was stabilized before measurement was made. Chromaticity coordinates, correlated color temperature and color rendering index were calculated from the spectral power distribution taken at 5 nm intervals over the range of 380 to 780 nm.</p>
<p>3) Electrical Measurements:</p> <p>Electrical parameters were measured using power meters incorporated in goniophotometer or sphere-spectroradiometer system. The ambient temperature surrounding the sample was maintained at 25°C±1°C. The sample was operated at 120 or rated Volts AC, 60Hz. It was stabilized before measurement was made. Voltage, frequency, current, power, power factor and total harmonic distortion were measured by and read from the power meter.</p>

2.1.1 Electrical, Photometric and Chromaticity Measurements

Test date	2023-06-21	Test Ambient:	25.3
Test Orientation	As intended	Stabilization Time (min)	15
Model Number	DLG0018(GF4)	CCT Setting	2700k

Electrical Measurement:

Sampel No.	Voltage (Vac)	Frequency (Hz)	Current (A)	Power (W)	Power Factor
#1	120	60	0.097	11.37	0.974

Chromaticity Measurement – Sphere-Spectroradiometer Method:

Parameter	Result	Special Color Rendering Indices			
Test Voltage (V)	120	R1	96	R9	65
Frequency (Hz)	60	R2	99	R10	97
CCT (K)	2778	R3	99	R11	98
Duv	0.00147	R4	95	R12	86
Chromaticity (x, y)	x=4561, y=0.4137	R5	96	R13	97
Chromaticity (u', v')	u' =0.2587, v' =0.5279	R6	98	R14	99
Color Rendering Index (CRI)	94.7	R7	92	R15	91
R9	65	R8	84	--	--

Photometric Measurement – Goniophotometer Method:

Parameter	Result
Test Voltage (V)	120
Frequency (Hz)	60
Total Luminous (lm)	902.87
Luminous Efficacy (lm/W)	79.41
Beam Angle (°)	39.6
Center Beam Candle Power (cd)	1704

Spectral Power Distribution & Chromaticity Diagram

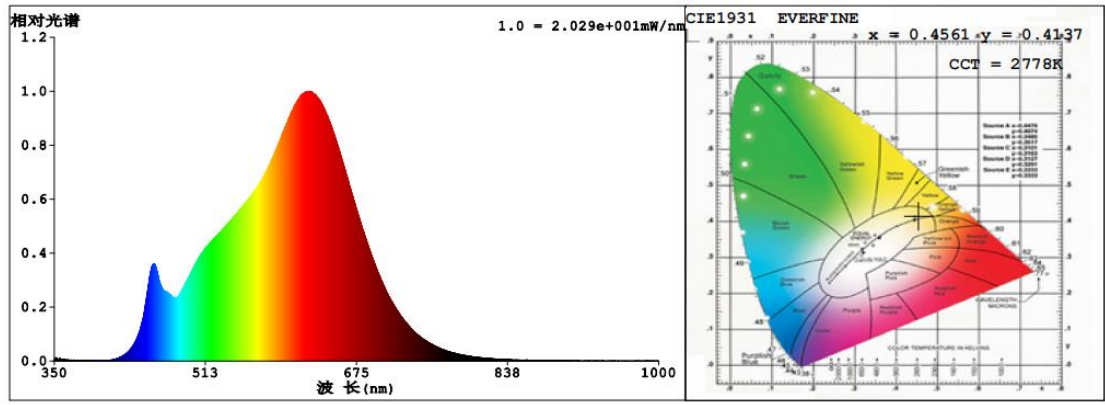

TM30

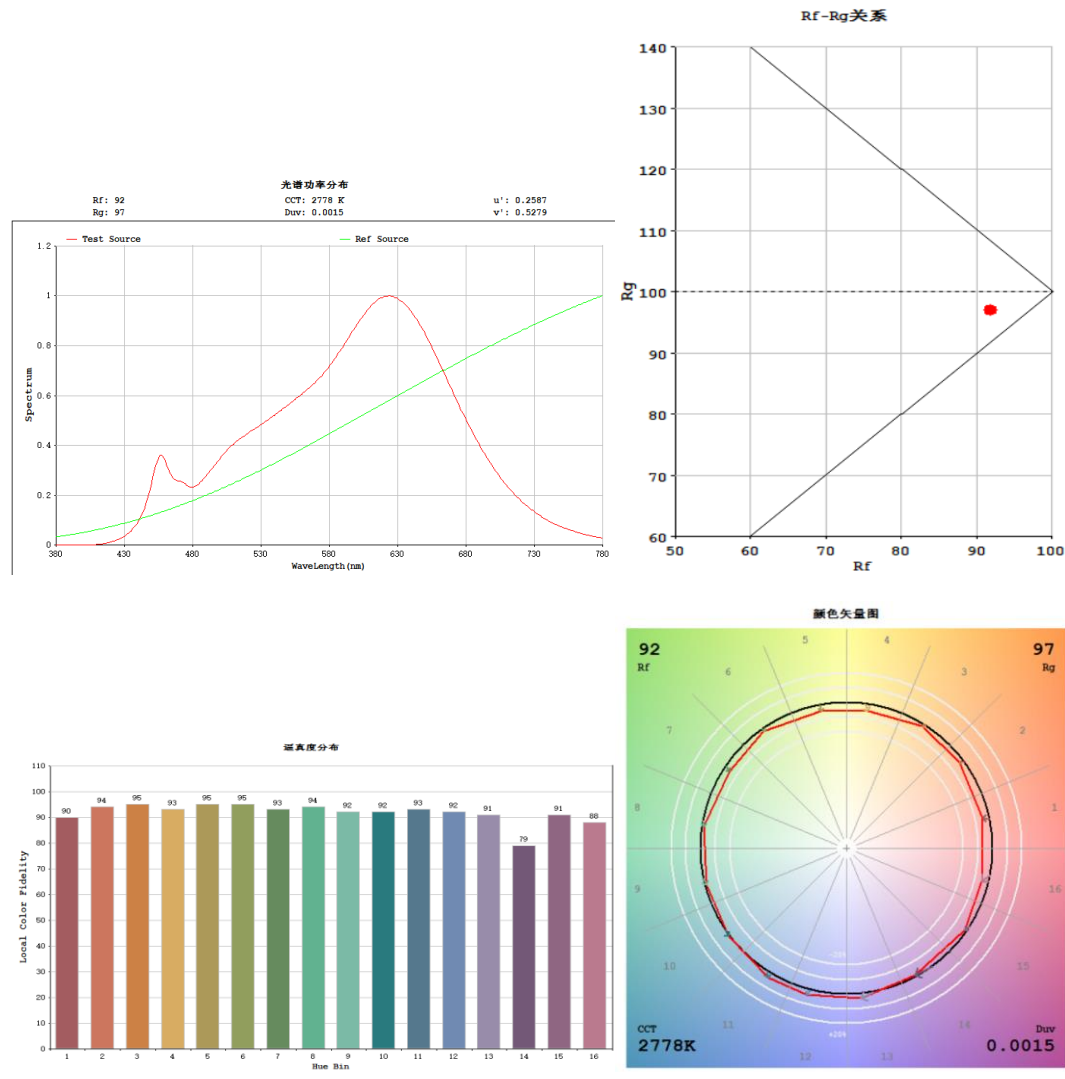

Zonal Lumen Tabulation

Zonal Lumen Summary		
Zone	Lumens	% Luminaire
0-30	716.0	79.3%
0-40	809.9	89.7%
0-60	877.6	97.2%
60-90	25.3	2.7%
70-100	8.1	0.9%
90-120	0.0	0.0%
0-90	902.9	100.0%
90-180	0.0	0.0%
0-180	902.9	100.0%

Lumens Per Zone					
Zone	Lumens	% Total	Zone	Lumens	% Total
0-10	155.3	17.2%	90-100	0	0%
10-20	332.3	36.8%	100-110	0	0%
20-30	228.4	25.3%	110-120	0	0%
30-40	93.3	10.4%	120-130	0	0%
40-50	41.9	4.6%	130-140	0	0%
50-60	26.6	2.9%	140-150	0	0%
60-70	16.5	1.9%	150-160	0	0%
70-80	7.6	0.8%	160-170	0	0%
80-90	0.9	0.1%	170-180	0	0%

Photometric Data

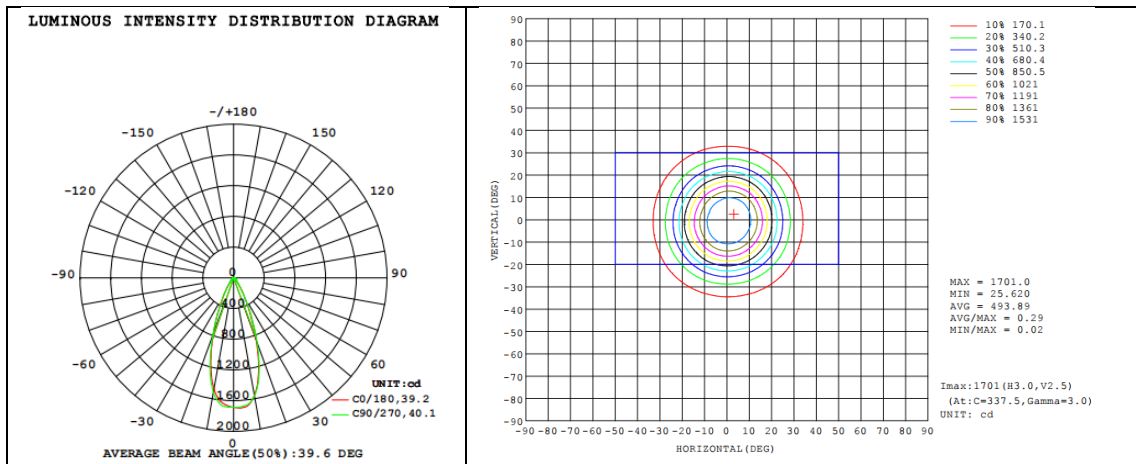

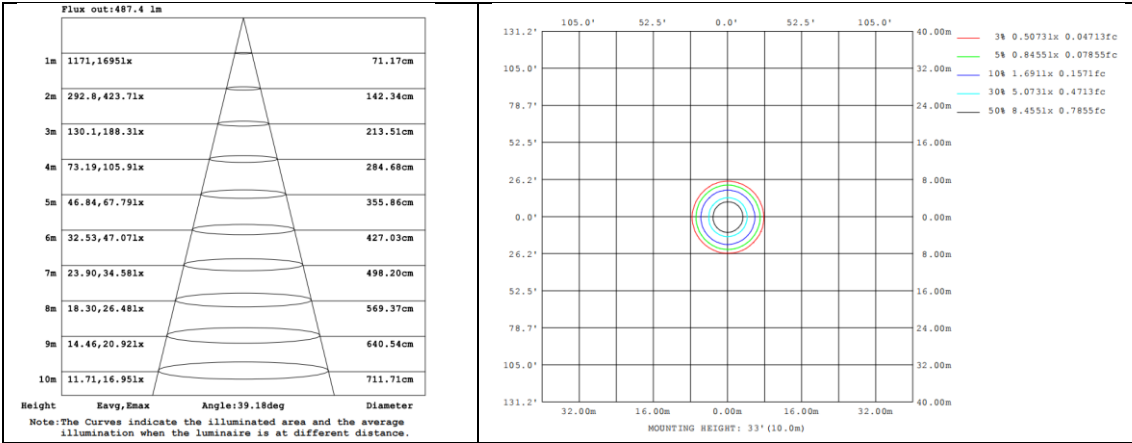

Table--1

UNIT: cd

γ (DEG)	C (DEG)																		
	0	22.5	45	67.5	90	112.5	135	157.5	180	202.5	225	247.5	270	292.5	315	337.5			
0	1688	1688	1688	1688	1688	1688	1688	1688	1688	1688	1688	1688	1688	1688	1688	1688			
5	1690	1689	1686	1682	1671	1669	1656	1644	1639	1637	1646	1657	1674	1690	1698	1697			
10	1560	1563	1566	1573	1562	1559	1530	1502	1473	1460	1472	1487	1517	1542	1556	1561			
15	1262	1275	1278	1298	1291	1279	1235	1196	1153	1133	1149	1163	1194	1218	1246	1249			
20	866	880	888	906	902	891	853	816	771	751	761	769	793	815	836	848			
25	509	529	534	545	543	536	509	487	457	441	439	439	454	464	479	489			
30	276	289	292	298	297	293	277	266	252	241	237	240	242	249	255	262			
35	151	156	159	161	159	155	147	137	130	127	126	131	131	135	138	142			
40	81.4	83.8	85.2	88.2	85.0	83.2	79.7	76.0	72.5	69.6	70.1	74.0	74.2	74.7	76.7	76.8			
45	53.1	54.1	55.2	57.7	56.8	56.6	54.9	52.5	49.8	48.2	48.7	51.0	51.4	51.1	51.9	51.5			
50	38.8	39.5	40.4	41.9	41.7	41.3	40.3	39.1	37.2	35.8	36.5	37.9	38.4	38.2	38.4	38.2			
55	29.3	29.8	30.4	31.2	31.2	30.9	30.1	29.4	28.1	27.2	27.7	28.9	28.8	28.8	28.9	28.8			
60	22.3	22.7	23.0	23.4	23.4	23.2	22.7	22.2	21.3	20.7	21.1	22.1	21.8	21.7	21.7	21.8			
65	16.6	17.0	17.2	17.4	17.4	17.3	16.9	16.6	16.0	15.4	15.7	16.2	16.1	16.0	16.0	16.2			
70	11.8	12.0	12.2	12.5	12.4	12.4	12.1	11.8	11.3	10.8	11.0	11.4	11.3	11.3	11.2	11.3			
75	7.39	7.69	7.86	8.14	8.06	6.52	7.64	7.52	7.00	6.55	6.64	6.89	6.80	6.77	6.79	6.94			
80	3.04	3.30	3.40	3.62	3.56	2.68	2.85	3.16	2.79	2.50	2.47	2.47	2.40	2.42	2.58	2.73			
85	0.56	0.61	0.68	0.66	0.65	0.56	0.63	0.60	0.50	0.45	0.35	0.34	0.28	0.34	0.37	0.47			
90	0.00	0.00	0.00	0.00	0.00	0.00	0.00	0.00	0.00	0.00	0.00	0.00	0.00	0.00	0.00	0.00			

2.1.2 Electrical, Photometric and Chromaticity Measurements

Test date	2023-06-21	Test Ambient:	25.3
Test Orientation	As intended	Stabilization Time (min)	15
Model Number	DLG0018 (GF4)	CCT Setting	3000k

Electrical Measurement:

Sampel No.	Voltage (Vac)	Frequency (Hz)	Current (A)	Power (W)	Power Factor
#1	120	60	0.095	11.17	0.973

Chromaticity Measurement - Sphere-Spectroradiometer Method:

Parameter	Result	Special Color Rendering Indices			
Test Voltage (V)	120	R1	97	R9	73
Frequency (Hz)	60	R2	99	R10	99
CCT (K)	3135	R3	97	R11	97
Duv	-0.000421	R4	95	R12	81
Chromaticity (x, y)	x=0.4271, y=0.3994	R5	96	R13	99
Chromaticity (u', v')	u' =0.2462, v' =0.5181	R6	96	R14	99
Color Rendering Index (CRI)	95.0	R7	92	R15	94
R9	73	R8	87	--	--

Photometric Measurement – Goniophotometer Method:

Parameter	Result
Test Voltage (V)	120
Frequency (Hz)	60
Total Luminous (lm)	972.30
Luminous Efficacy (lm/W)	87.08
Beam Angle (°)	39.7
Center Beam Candle Power (cd)	1825

Spectral Power Distribution & Chromaticity Diagram

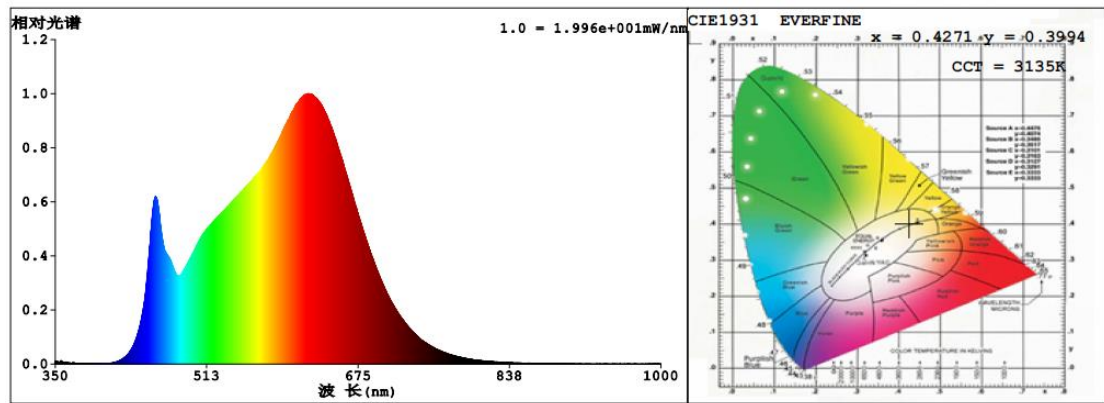

TM30

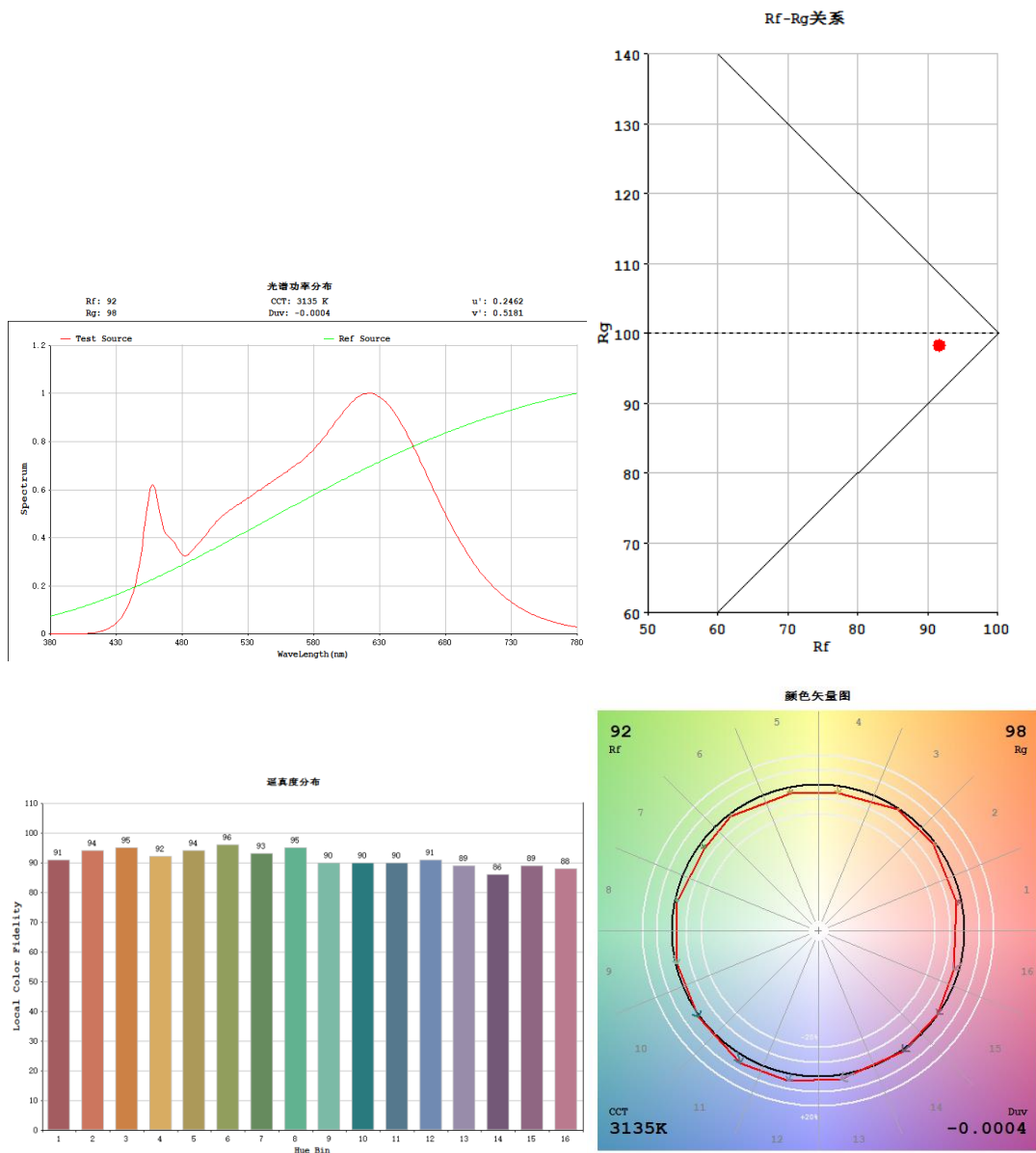

Zonal Lumen Tabulation

Zonal Lumen Summary		
Zone	Lumens	% Luminaire
0-30	770.1	79.2%
0-40	871.2	89.6%
0-60	945.1	97.2%
60-90	27.2	2.7%
70-100	8.8	0.9%
90-120	0.0	0.0%
0-90	972.3	100.0%
90-180	0.0	0.0%
0-180	972.3	100.0%

Lumens Per Zone					
Zone	Lumens	% Total	Zone	Lumens	% Total
0-10	166.3	17.1%	90-100	0	0%
10-20	357.8	36.8%	100-110	0	0%
20-30	246.0	25.3%	110-120	0	0%
30-40	101.1	10.4%	120-130	0	0%
40-50	45.7	4.7%	130-140	0	0%
50-60	28.2	2.9%	140-150	0	0%
60-70	18.5	1.9%	150-160	0	0%
70-80	7.8	0.8%	160-170	0	0%
80-90	1.0	0.1%	170-180	0	0%

Photometric Data

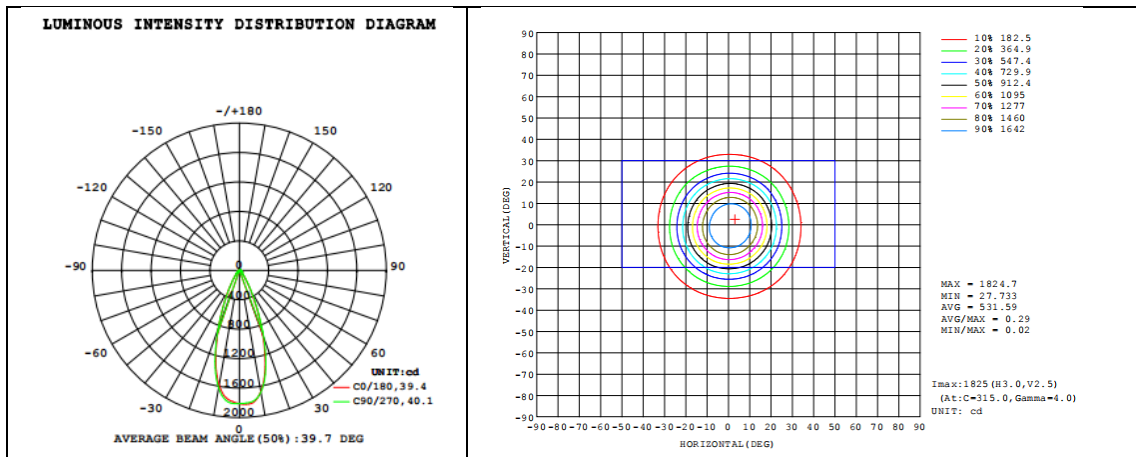

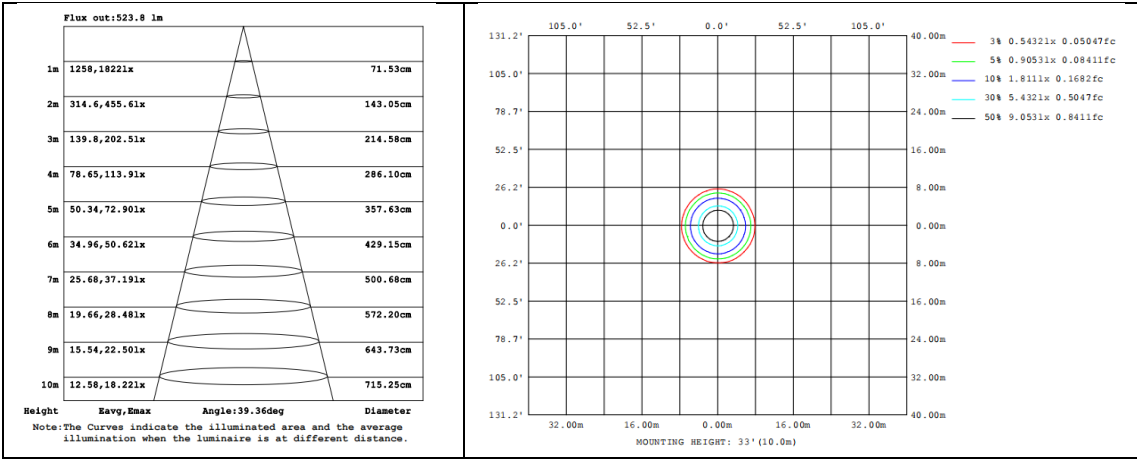

Table--1

UNIT: cd

C (DEG)	0	22.5	45	67.5	90	112.5	135	157.5	180	202.5	225	247.5	270	292.5	315	337.5			
0	1811	1811	1811	1811	1811	1811	1811	1811	1811	1811	1811	1811	1811	1811	1811	1811			
5	1816	1812	1808	1803	1796	1792	1775	1763	1759	1760	1767	1780	1793	1812	1823	1818			
10	1675	1679	1684	1688	1680	1671	1641	1612	1585	1574	1582	1598	1627	1652	1664	1675			
15	1359	1372	1379	1396	1388	1372	1323	1282	1245	1223	1234	1247	1283	1309	1336	1340			
20	935	951	959	976	970	959	915	879	838	814	818	826	851	874	901	913			
25	550	572	578	587	586	577	548	524	497	478	473	472	489	500	516	528			
30	298	312	316	322	322	315	299	286	273	262	259	258	265	268	276	282			
35	163	169	172	175	173	167	158	148	142	138	136	141	142	146	148	153			
40	88.2	90.9	92.4	95.3	91.7	89.7	85.9	82.1	79.0	75.7	75.8	79.7	80.1	80.5	82.5	82.9			
45	57.7	58.7	59.8	62.4	61.3	61.0	59.0	56.7	54.3	52.4	52.6	54.9	55.5	55.1	56.0	55.5			
50	42.1	42.9	43.8	45.2	45.1	44.6	43.4	42.2	40.4	38.9	39.5	41.0	41.4	41.2	41.3	41.2			
55	31.8	32.4	33.0	33.7	33.7	33.2	32.4	31.7	30.5	29.6	30.0	31.2	31.2	31.1	31.1	31.1			
60	24.1	24.6	24.9	25.3	25.2	25.0	24.4	24.0	23.1	22.5	22.8	23.6	23.5	23.3	23.5	23.5			
65	18.0	18.3	18.6	18.9	18.8	18.6	18.3	17.9	17.3	16.7	16.9	17.5	17.4	17.2	17.3	17.4			
70	12.7	13.0	13.2	13.5	13.4	13.3	13.1	12.8	12.3	11.7	11.9	12.3	12.2	12.2	12.2	12.2			
75	7.96	8.30	8.51	8.81	8.72	7.10	8.35	8.14	7.66	7.13	7.18	7.44	7.35	7.30	7.36	7.48			
80	3.27	3.54	3.71	3.93	3.87	3.06	3.09	3.43	3.07	2.75	2.67	2.66	2.59	2.63	2.81	2.95			
85	0.59	0.66	0.75	0.67	0.68	0.64	0.68	0.66	0.58	0.50	0.39	0.36	0.32	0.38	0.41	0.52			
90	0.00	0.00	0.00	0.00	0.00	0.00	0.00	0.00	0.00	0.00	0.00	0.00	0.00	0.00	0.00	0.00			

2.1.3 Electrical, Photometric and Chromaticity Measurements

Test date	2023-06-21	Test Ambient:	25.3
Test Orientation	As intended	Stabilization Time (min)	15
Model Number	DLG0018 (GF4)	CCT Setting	3500k

Electrical Measurement:

Sampel No.	Voltage (Vac)	Frequency (Hz)	Current (A)	Power (W)	Power Factor
#1	120	60	0.093	10.91	0.972

Chromaticity Measurement - Sphere-Spectroradiometer Method:

Parameter	Result	Special Color Rendering Indices			
Test Voltage (V)	120	R1	98	R9	77
Frequency (Hz)	60	R2	99	R10	99
CCT (K)	3591	R3	98	R11	96
Duv	-0.000767	R4	94	R12	77
Chromaticity (x, y)	x=0.3996, y=0.3861	R5	96	R13	99
Chromaticity (u', v')	u' =0.2339, v' =0.5085	R6	96	R14	99
Color Rendering Index (CRI)	95.0	R7	92	R15	95
R9	77	R8	88	--	--

Photometric Measurement – Goniophotometer Method:

Parameter	Result
Test Voltage (V)	120
Frequency (Hz)	60
Total Luminous (lm)	1037.0
Luminous Efficacy (lm/W)	95.09
Beam Angle (°)	39.8
Center Beam Candle Power (cd)	1939

Spectral Power Distribution & Chromaticity Diagram

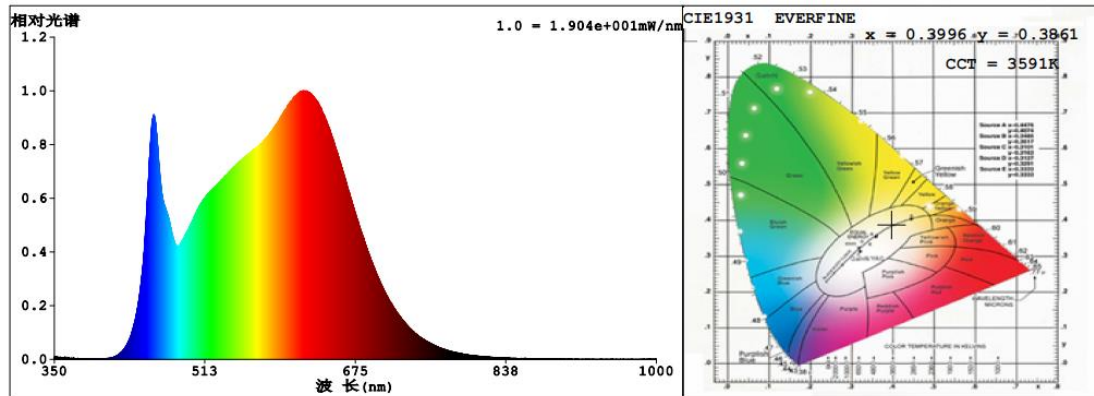

TM30

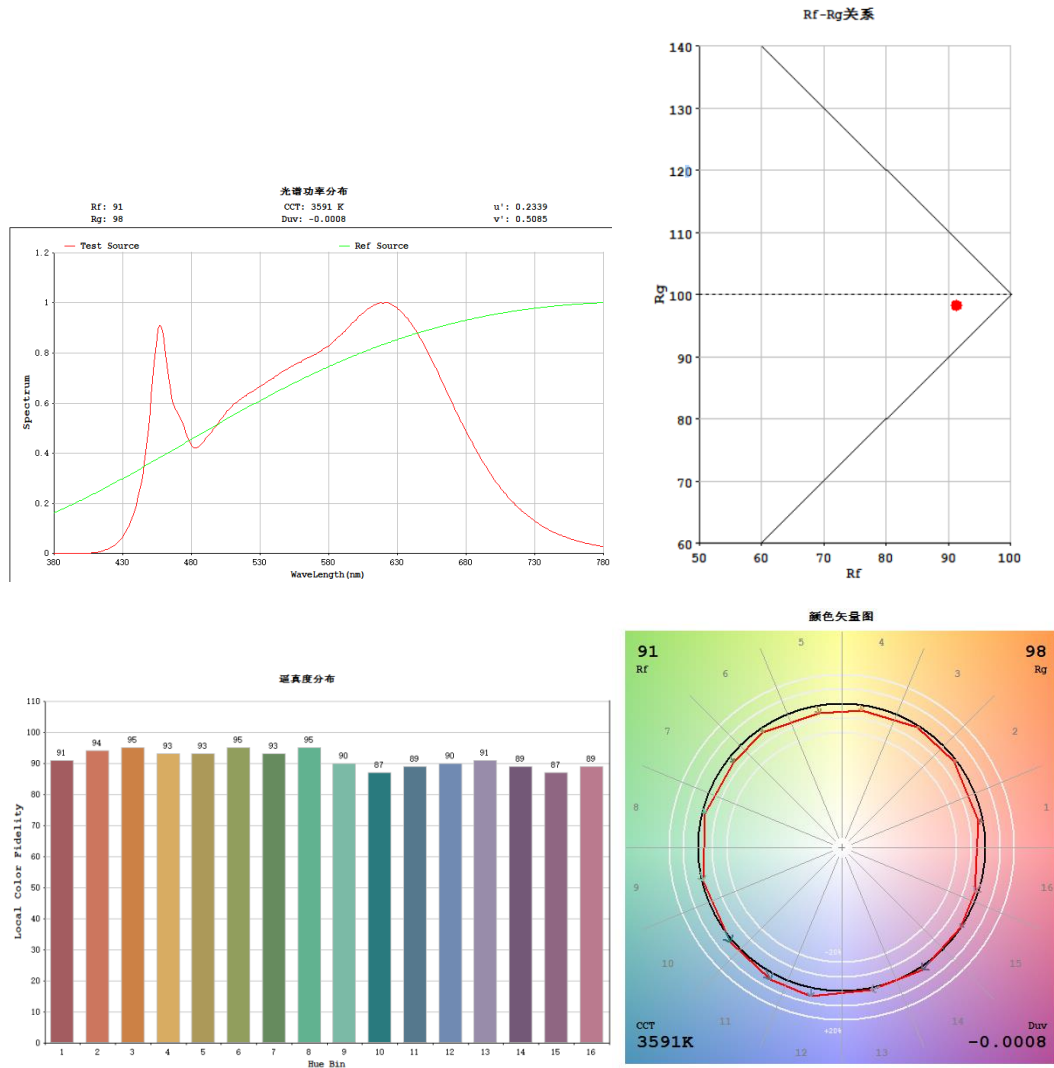

Zonal Lumen Tabulation

Zonal Lumen Summary		
Zone	Lumens	% Luminaire
0-30	820.3	79.2%
0-40	928.1	89.6%
0-60	1008.0	97.2%
60-90	29.0	2.7%
70-100	10.4	0.9%
90-120	0.0	0.0%
0-90	1037.0	100.0%
90-180	0.0	0.0%
0-180	1037.0	100.0%

Lumens Per Zone					
Zone	Lumens	% Total	Zone	Lumens	% Total
0-10	176.3	17.0%	90-100	0	0%
10-20	380.6	36.7%	100-110	0	0%
20-30	263.4	25.4%	110-120	0	0%
30-40	107.8	10.4%	120-130	0	0%
40-50	48.7	4.7%	130-140	0	0%
50-60	31.1	3.0%	140-150	0	0%
60-70	18.7	1.8%	150-160	0	0%
70-80	9.3	0.9%	160-170	0	0%
80-90	1.0	0.1%	170-180	0	0%

Photometric Data

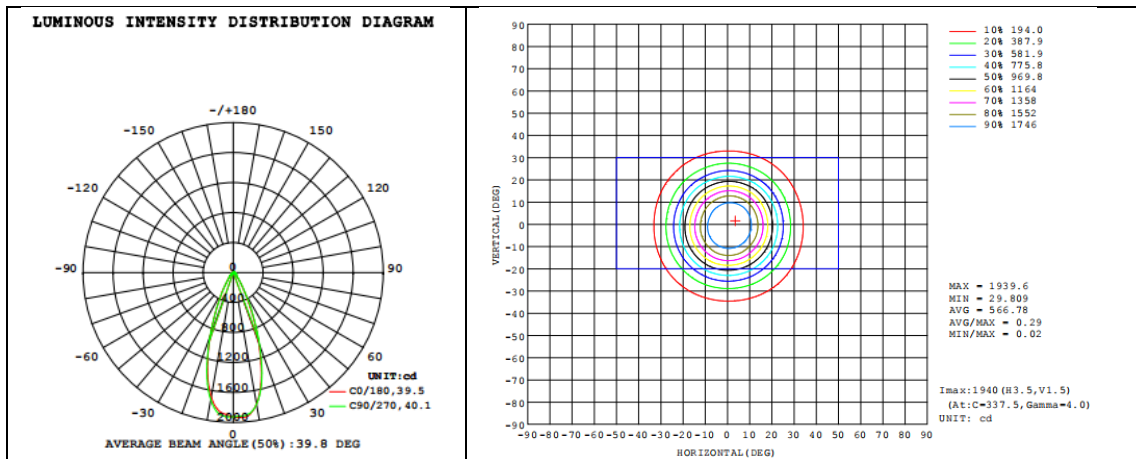

2.1.4 Electrical, Photometric and Chromaticity Measurements

Test date	2023-06-21	Test Ambient:	25.3
Test Orientation	As intended	Stabilization Time (min)	15
Model Number	DLG0018 (GF4)	CCT Setting	4000k

Electrical Measurement:

Sampel No.	Voltage (Vac)	Frequency (Hz)	Current (A)	Power (W)	Power Factor
#1	120	60	0.094	10.99	0.973

Chromaticity Measurement - Sphere-Spectroradiometer Method:

Parameter	Result	Special Color Rendering Indices			
Test Voltage (V)	120	R1	97	R9	77
Frequency (Hz)	60	R2	99	R10	99
CCT (K)	3985	R3	98	R11	94
Duv	-0.00001	R4	92	R12	74
Chromaticity (x, y)	x=0.3811, y=0.3771	R5	94	R13	99
Chromaticity (u', v')	u' =0.2254, v' =0.5018	R6	96	R14	100
Color Rendering Index (CRI)	94.7	R7	92	R15	94
R9	77	R8	88	--	--

Photometric Measurement – Goniophotometer Method:

Parameter	Result
Test Voltage (V)	120
Frequency (Hz)	60
Total Luminous (lm)	1066.6
Luminous Efficacy (lm/W)	97.06
Beam Angle (°)	39.9
Center Beam Candle Power (cd)	1990

Spectral Power Distribution & Chromaticity Diagram

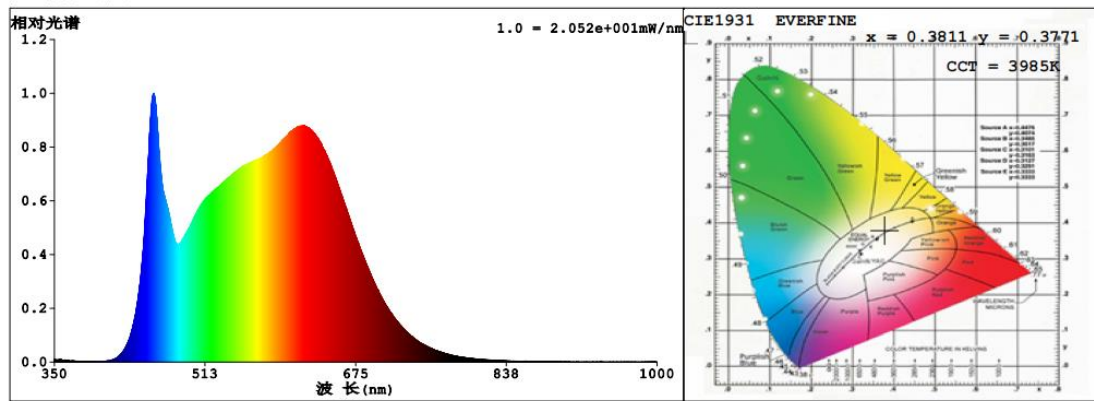

TM30

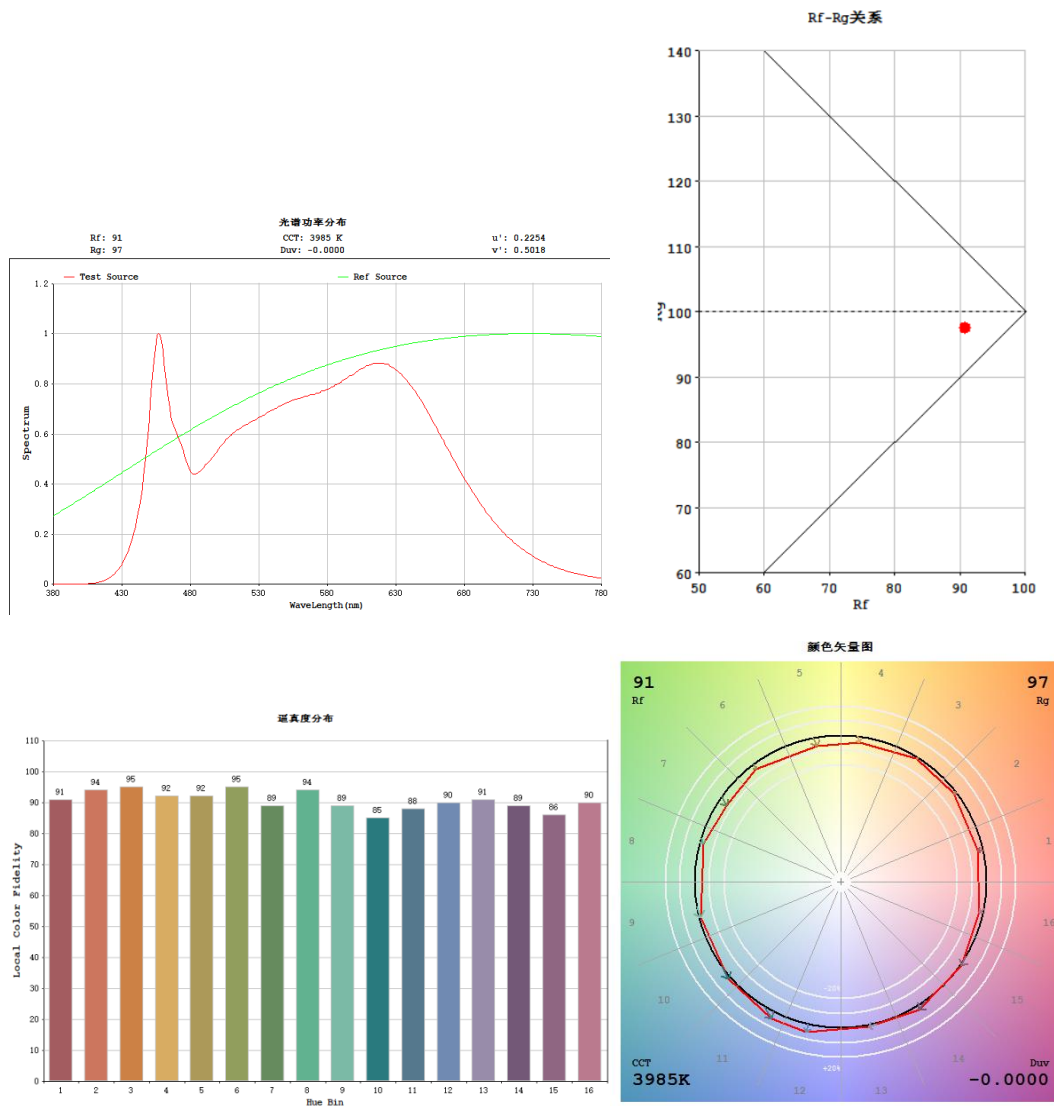

Zonal Lumen Tabulation

Zonal Lumen Summary		
Zone	Lumens	% Luminaire
0-30	843.7	79.1%
0-40	954.6	89.5%
0-60	1036.7	97.2%
60-90	29.9	2.7%
70-100	10.7	1.0%
90-120	0.0	0.0%
0-90	1066.6	100.0%
90-180	0.0	0.0%
0-180	1066.6	100.0%

Lumens Per Zone					
Zone	Lumens	% Total	Zone	Lumens	% Total
0-10	181.3	17.0%	90-100	0	0%
10-20	391.4	36.7%	100-110	0	0%
20-30	270.9	25.4%	110-120	0	0%
30-40	110.9	10.4%	120-130	0	0%
40-50	50.1	4.7%	130-140	0	0%
50-60	32.0	3.0%	140-150	0	0%
60-70	19.2	1.8%	150-160	0	0%
70-80	9.6	0.9%	160-170	0	0%
80-90	1.1	0.1%	170-180	0	0%

Photometric Data

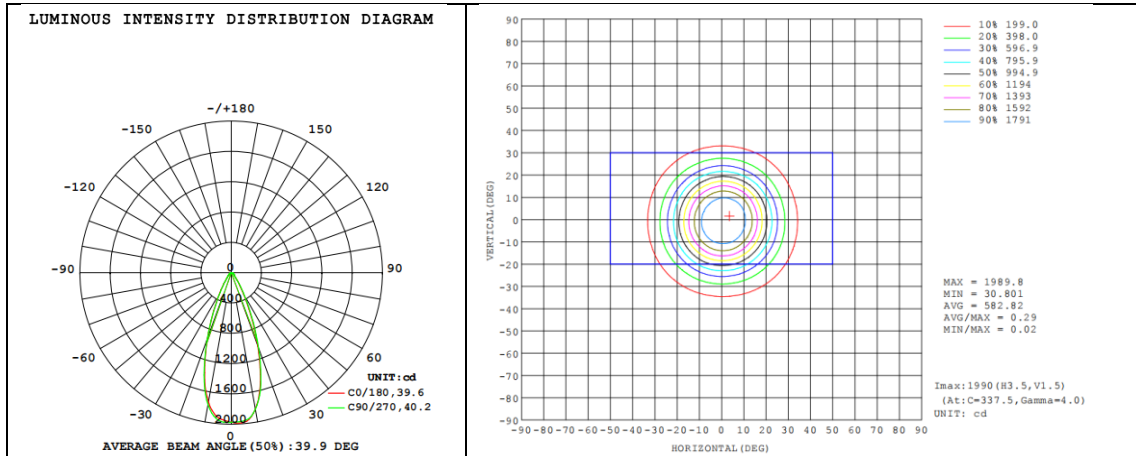

2.1.5 Electrical, Photometric and Chromaticity Measurements

Test date	2023-06-21	Test Ambient:	25.3
Test Orientation	As intended	Stabilization Time (min)	15
Model Number	DLG0018 (GF4)	CCT Setting	5000k

Electrical Measurement:

Sampel No.	Voltage (Vac)	Frequency (Hz)	Current (A)	Power (W)	Power Factor
#1	120	60	0.097	11.39	0.974

Chromaticity Measurement - Sphere-Spectroradiometer Method:

Parameter	Result	Special Color Rendering Indices			
Test Voltage (V)	120	R1	93	R9	65
Frequency (Hz)	60	R2	97	R10	92
CCT (K)	4962	R3	98	R11	89
Duv	0.00379	R4	88	R12	66
Chromaticity (x, y)	x=0.3469, y=0.3607	R5	90	R13	94
Chromaticity (u', v')	u' =0.2092, v' =0.4893	R6	94	R14	99
Color Rendering Index (CRI)	92.0	R7	92	R15	89
R9	65	R8	85	--	--

Photometric Measurement – Goniophotometer Method:

Parameter	Result
Test Voltage (V)	120
Frequency (Hz)	60
Total Luminous (lm)	1070.07
Luminous Efficacy (lm/W)	93.99
Beam Angle (°)	40.0
Center Beam Candle Power (cd)	1990

Spectral Power Distribution & Chromaticity Diagram

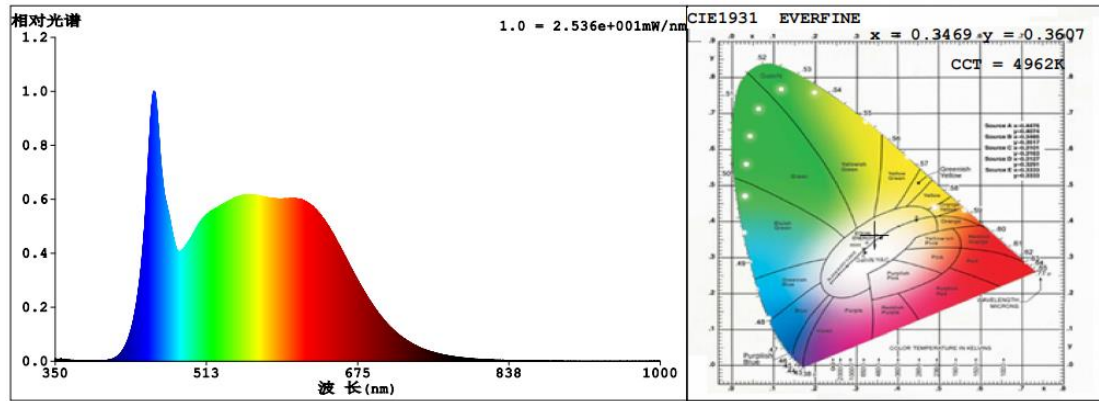

TM30

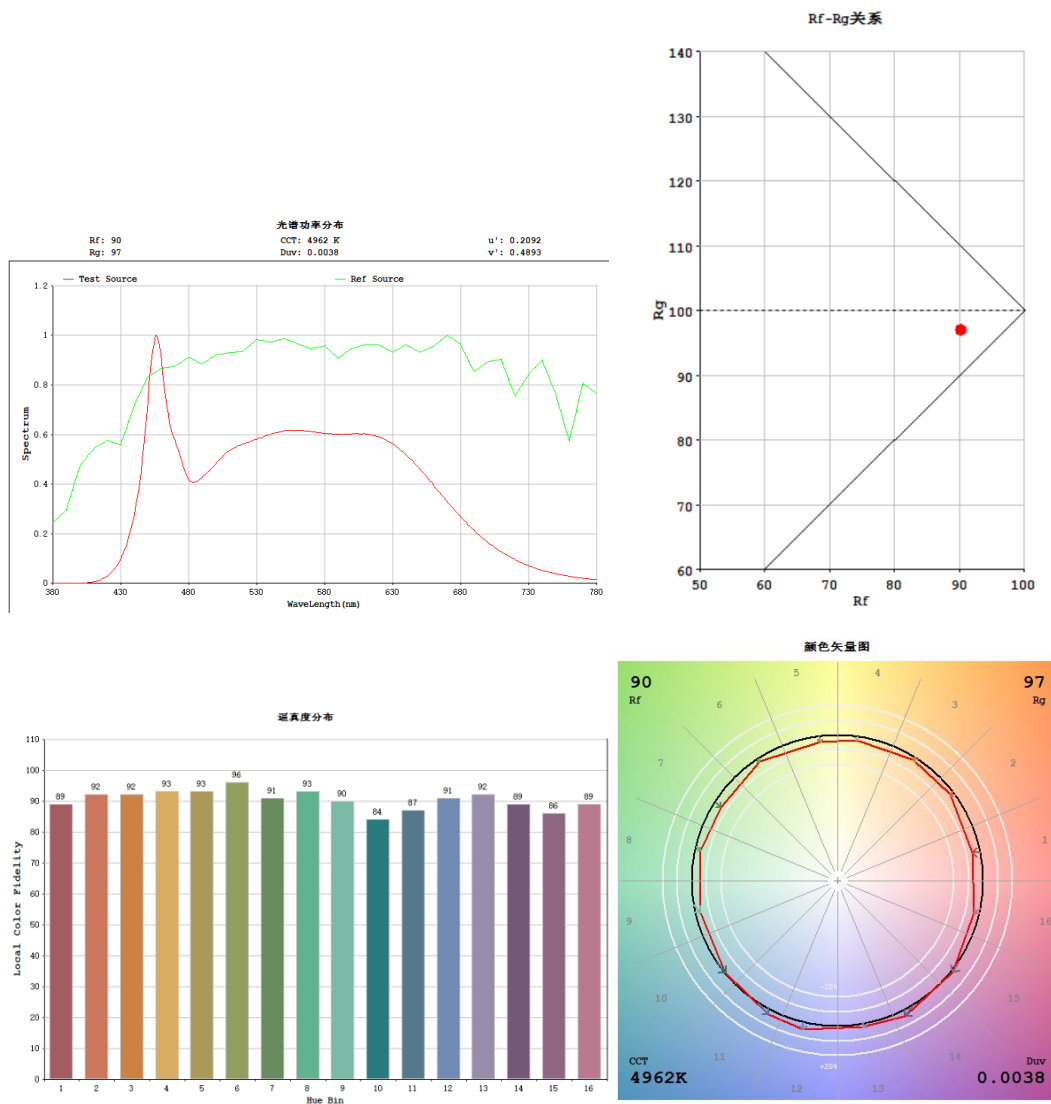

Zonal Lumen Tabulation

Zonal Lumen Summary		
Zone	Lumens	% Luminaire
0-30	845.3	79.0%
0-40	957.7	89.5%
0-60	1040.0	97.2%
60-90	30.0	2.7%
70-100	10.7	1.0%
90-120	0.0	0.0%
0-90	1070.0	100.0%
90-180	0.0	0.0%
0-180	1070.0	100.0%

Lumens Per Zone					
Zone	Lumens	% Total	Zone	Lumens	% Total
0-10	180.8	16.9%	90-100	0	0%
10-20	391.6	36.6%	100-110	0	0%
20-30	272.9	25.5%	110-120	0	0%
30-40	112.4	10.5%	120-130	0	0%
40-50	50.3	4.7%	130-140	0	0%
50-60	32.1	3.0%	140-150	0	0%
60-70	19.3	1.8%	150-160	0	0%
70-80	9.6	0.9%	160-170	0	0%
80-90	1.1	0.1%	170-180	0	0%

Photometric Data

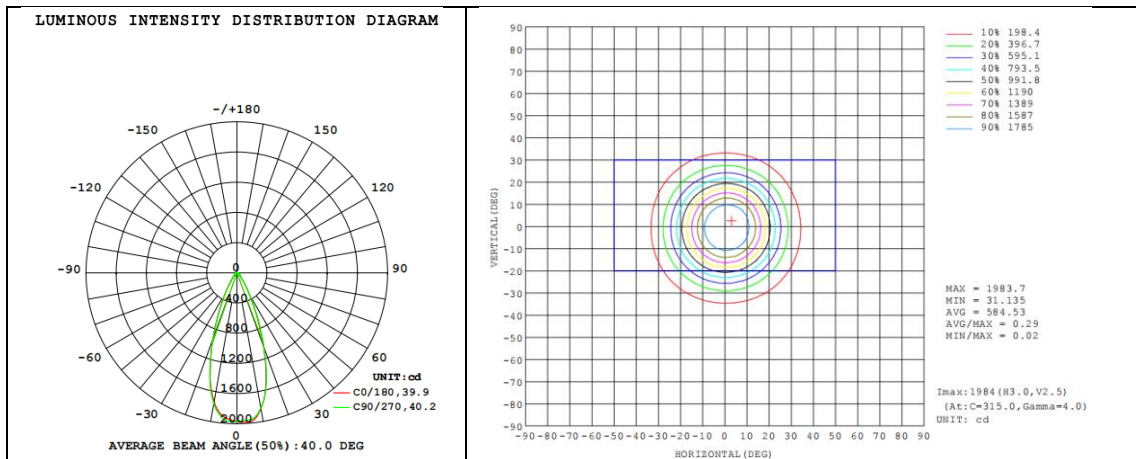

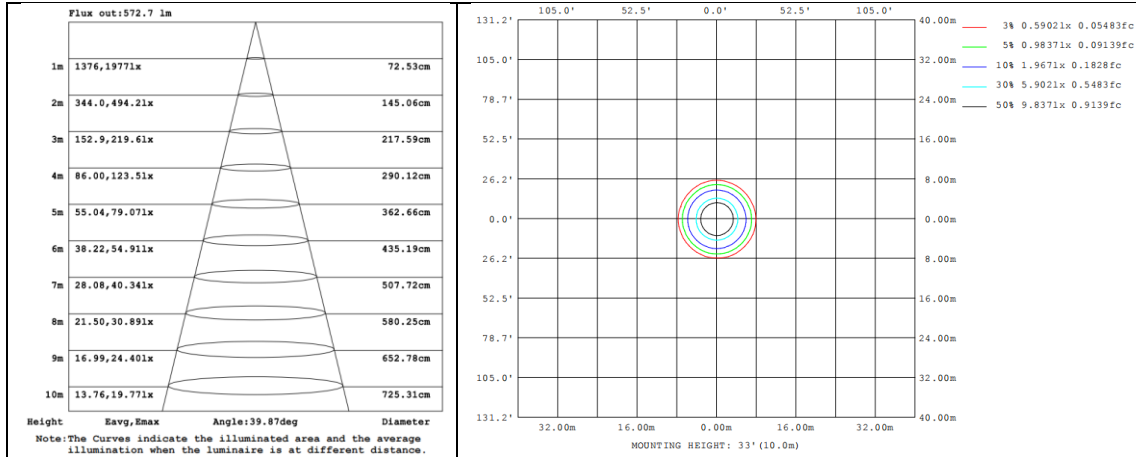

Table--1

UNIT: cd

C (DEG)	C (DEG)															
	0	22.5	45	67.5	90	112.5	135	157.5	180	202.5	225	247.5	270	292.5	315	337.5
0	1969	1969	1969	1969	1969	1969	1969	1969	1969	1969	1969	1969	1969	1969	1969	1969
5	1981	1980	1969	1960	1953	1942	1936	1920	1919	1921	1921	1936	1945	1962	1980	1974
10	1834	1839	1840	1843	1822	1809	1788	1760	1739	1724	1727	1741	1763	1789	1826	1828
15	1500	1514	1517	1525	1510	1488	1447	1408	1376	1355	1358	1363	1392	1425	1461	1469
20	1041	1058	1061	1066	1058	1043	1005	965	932	906	903	903	934	953	993	1007
25	616	637	641	650	642	628	603	579	555	534	525	521	538	551	570	585
30	334	348	351	356	354	347	330	318	304	292	288	286	292	295	306	314
35	183	189	192	193	191	184	175	165	159	156	152	156	157	161	165	170
40	99.8	103	103	106	101	98.7	95.0	91.5	89.2	85.5	84.9	88.1	88.3	88.9	91.6	93.0
45	65.5	66.8	67.1	68.9	67.6	66.9	65.2	63.1	61.6	59.5	58.7	60.7	61.2	60.9	62.0	62.2
50	47.7	48.6	49.1	50.0	49.7	49.0	48.1	47.1	45.9	43.9	44.0	45.3	45.7	45.4	45.9	46.1
55	35.8	36.5	36.8	37.3	37.2	36.7	36.0	35.2	34.4	33.2	33.3	34.5	34.5	34.3	34.5	34.6
60	27.1	27.6	27.8	28.1	27.9	27.7	27.2	26.6	26.0	25.1	25.3	26.2	26.0	25.8	26.1	26.2
65	20.1	20.5	20.7	20.9	20.8	20.7	20.3	19.9	19.4	18.7	18.8	19.4	19.3	19.1	19.3	19.4
70	14.2	14.5	14.7	15.0	14.9	14.8	14.5	14.2	13.7	12.5	13.2	13.6	13.6	13.4	13.5	13.6
75	8.88	9.28	9.50	9.79	9.70	8.06	9.37	9.08	8.56	7.99	8.00	8.28	8.18	8.11	8.18	8.37
80	3.66	3.98	4.15	4.38	4.33	3.49	3.54	3.82	3.47	3.11	3.01	3.00	2.91	2.93	3.15	3.32
85	0.68	0.75	0.84	0.67	0.74	0.75	0.76	0.75	0.67	0.58	0.46	0.42	0.38	0.43	0.48	0.60
90	0.00	0.00	0.00	0.00	0.00	0.00	0.00	0.00	0.00	0.00	0.00	0.00	0.00	0.00	0.00	0.00

Model Number	CCT setting	Test Voltage(V)	Flux(lm)	P(W)	Luminous Efficacy lm/W
DLG0018(GF4)	2700K setting	120	902.875	11.37	79.41
	3000K setting	120	972.297	11.17	87.08
	3500K setting	120	1037.01	10.91	95.09
	4000K setting	120	1066.61	10.99	97.06
	5000K setting	120	1070.07	11.39	93.99